

VERT[®] Filter List

VERT certified[®]
Particle Filter Systems
for Combustion Engines

April 2016



Legal status

This VERT® Filter List is an international industrial standard, not legally binding as such: this standard has however become a legally binding code in several countries for different applications where authorities require “Best Available Technology”.

Imprint

Publisher

VERT® Association, a non-profit organization registered in Switzerland, Kanton Aargau. Trade Registry is no CH-400.6.031.438-9. VERT® aims to establish the Best Available Technology BAT for combustion engine exhaust emission control, both retrofits and original equipment as well as to assure best retrofit practice for retrofit and quality control.

Authors

The Scientific Committee
of the VERT® Association
A. Mayer, TTM^{*)}
J. Lemaire, AEEDA
J. Czerwinski, AFHB

Citation suggestion

VERT® Filter List 2016-1

Download

www.VERT-certification.eu

VERT® Association,
Volker Hensel, CEO
Schiffgasse 4a,
D – 69117 Heidelberg
Tel. +49 174 864 64 64
volker.hensel@aurigna.com

VERT Filter Certification Office

A. Mayer, TTM
Fohrhölzlistrasse 14b,
CH-5443 Niederrohrdorf, Switzerland
Tel. +41(56)496 6414
ttm.a.mayer@bluewin.ch

^{*)} Acronyms see chap. 5

Contents

Preface	1
Introduction	2
1. VERT[®] testing of particle filter systems	3
1.1. Particle filter systems for retrofitting	4
1.2. Particle filter systems as original equipment	4
1.3. Re-certification after technical alterations	4
1.4. Approval of filter media	4
1.5. Approval of regeneration additives	5
1.6. Approval of OBM units	5
1.7. Verification of conformity after 3 years	5
1.8. PFS manufacturers' responsibility	5
1.9. Non-transferability of the VERT [®] certificate	5
2. VERT[®] PFS - Approval Criteria	6
2.1. Curtailing particle emissions	6
2.2. Legislated emission limits	6
2.3. Secondary emissions	6
2.4. Pressure loss	7
2.5. Additive dosage	7
2.6. Function monitoring OBD (minimal requirements)	7
2.7. Noise Attenuation	7
2.8. Durability, Maintenance and Warranty	7
2.9. Labeling	8
2.10. Flow direction	8
2.11. Safety	8
2.12. Bypass	8
2.13. Diagnosis access	8
2.14. Cleaning and disposal	8
2.15. Substituting mufflers for PFS	8
2.16. Technical reporting the retrofit	8
2.17. COP = Conformity of Production	9
2.18. IUC = In Use Compliance Tests	9
2.19. Operation Manual	9
2.20. Impact on Energy Consumption	9
2.21. Criteria for VERTdePN-Systems	9
3. VERT[®] List of approved systems and components	10
3.1. Particle filter systems for prolonged deployment	10
3.2. On-board monitoring (OBM)	18
3.3. Particle filter systems for short duration usage	18
3.4. Particle filter media	20
3.5. Regeneration additive (FBC)	21
3.6. Particle filter systems with sales volume < 50 p.a.	22
3.7. VERTdePN-Systems: Filtration + NOx-reduction	22
4. Self commitments of VERT[®] certified Manufacturers & Retrofitters	23
5. Recognition of the VERT[®] filter list	24
6. VERT[®] accredited test centers	24
7. Obtaining the VERT[®] certificate for manufacturing PFS	24
8. Address list	26
9. Acronyms	30
10. References	31
11. Appendices	32
11.1. VERT [®] Acceptance Test Report for PFS	32
11.2. Das VERT [®] - Gütesiegel	33
11.3. Particle Filter Systems for Internal Combustion Engines	34



Preface

Worldwide efforts, to curtail particle emissions from combustion engines, have produced a plethora of technologies. Not all of them are Best Available Technology as required by law to eliminate carcinogenic substances. The project VERT had been the pioneer from 1993. The AKPF (Working Group for Particle Filters) subsequently collaborated with the regulatory authorities and industrial partners to formulate a set of criteria. These include highest requirements in filtering the alveoli-intruding solid particles, preventing secondary emissions, guarantee dependability and cost effectiveness of the systems and assure best retrofit practice. VERT[®] only approves systems, which comply with the BAT definition and are proven in field deployment; both new and retrofitted older deployed Diesel engines.

High filter quality also results in cost effectiveness because it diminishes treatment costs for many serious ailments. These include cancer, cardiovascular, allergies, asthma and probably even Parkinson's, Alzheimer's and other widespread diseases. VERT[®] is highly committed to implement the latest medical and scientific findings. The filter approval criteria will be periodically adapted to reflect technological advances. Hence, this filter list will be updated twice a year.

The VERT[®] Association aims to provide methods to very efficiently combat both emission toxicity and black carbon induced global warming. Particle filters facilitate a sustainable environment.

A handwritten signature in dark ink, consisting of several loops and a long horizontal stroke extending to the right.

Lars C.Larsen
President VERT[®] Association

Introduction

Nanoscale solid particles from combustion engines have long been classified “Toxic air contaminant TOC” in environmental legislation [1,2], but are now classified “carcinogen for human” by WHO in Juni 2012 [15]. Hence, it is mandatory to diminish those emission components using the best available technology. The VERT Project [3] conducted comprehensive R&D and multi-year field testing of construction machines. The test proved functional particle filter systems having filtration rates exceeding 99% in the entire 20 – 300 nm range of alveoli intruding particles. Meanwhile, there are about 500,000 particle filter systems (PFS) retrofitted and 100 million ex-factory fitted PFS in LD- and HD-vehicles. This comprehensively confirms filter efficacy. Highly efficient filtration of solid fine particles from engine combustion is an established technical standard [4].

Regulatory authorities, engine manufacturers and customers have a range of expectations from such retrofit PFS. The VERT[®] partners therefore have defined specifications and criteria [5], which are based on a broad consensus for evaluating PFS as well as for matching filters to engines, installing and maintaining filter systems properly. These specifications and criteria are subject to progress, hence they have a dynamic character and they are therefore periodically updated to benefit from the latest scientific insights and technical advances.

Thorough investigation showed that not all PFS attained the best possible performance. Thus a suitability test became necessary. There are two special aspects of these suitability tests. First, these tests are confined to a single PFS, which is representative for a particle filter family of the same technology, and tested on an engine at highest space velocity. Second, these PFS must be tested for emissions in a range of operating conditions comprising new, soot loaded and regenerated, at steady-state as well as at transient operation, and during regeneration. Moreover, catalyst (coating and additives) promoted particle filter systems must be tested for toxic secondary emissions, defined as reaction products generated by the filter system. Finally, the PFS are retested after at least 2,000 hours of monitored real world deployment.

Only systems having successfully completed all VERT[®] suitability tests, are enrolled in this VERT[®] filter list and thus recommended for deployment. Successful completion of these tests on a test engine at highest space velocity, ensures that equally good filtration, without secondary emissions, are attainable for other engine applications, too. Effective regeneration under all possible operating conditions, however, is not proven by these tests and cannot be proven in this general sense. The regeneration procedure must therefore be selected and adapted for the specific deployment by the DPF retrofitter and he must guarantee for selecting a particular technology. Proper installation and maintenance are decisive for functionality; therefore VERT has also established rules for best retrofit practice.

To designate machines fitted with approved filter systems, the VERT[®] Association provides a quality label with a running number. All such fitted vehicles and equipment are registered in a publicly accessible database containing the technical data obtained during filter commissioning. The manufacturer must perform spot checks on machines equipped with VERT[®] approved PFS. The inspection results shall be annually submitted to the VERT[®] Association. If the statistics show that more than 5% of the installed systems from a PFS family fail, then that PFS is deleted from the VERT[®] filter list. It can only be reinstated in the VERT[®] filter list after the necessary technical improvements and after successful retesting the suitability.

Enrolment in the VERT[®] filter list commits the PFS manufacturer to only market VERT[®] labelled technology that is identical with the scope of the suitability tests and the certified state. Moreover, the manufacturer must monitor the quality of the PFS in cooperation with his retrofitter enterprises and comply with the rules in this VERT[®] filter list. Infringements of this self-commitments may result in deletion from the VERT[®] filter list.

1. VERT[®] testing of particle filter systems

The VERT[®] tests, in place since 1997, is now codified by the Swiss Technical Standard SN 277206 [6]

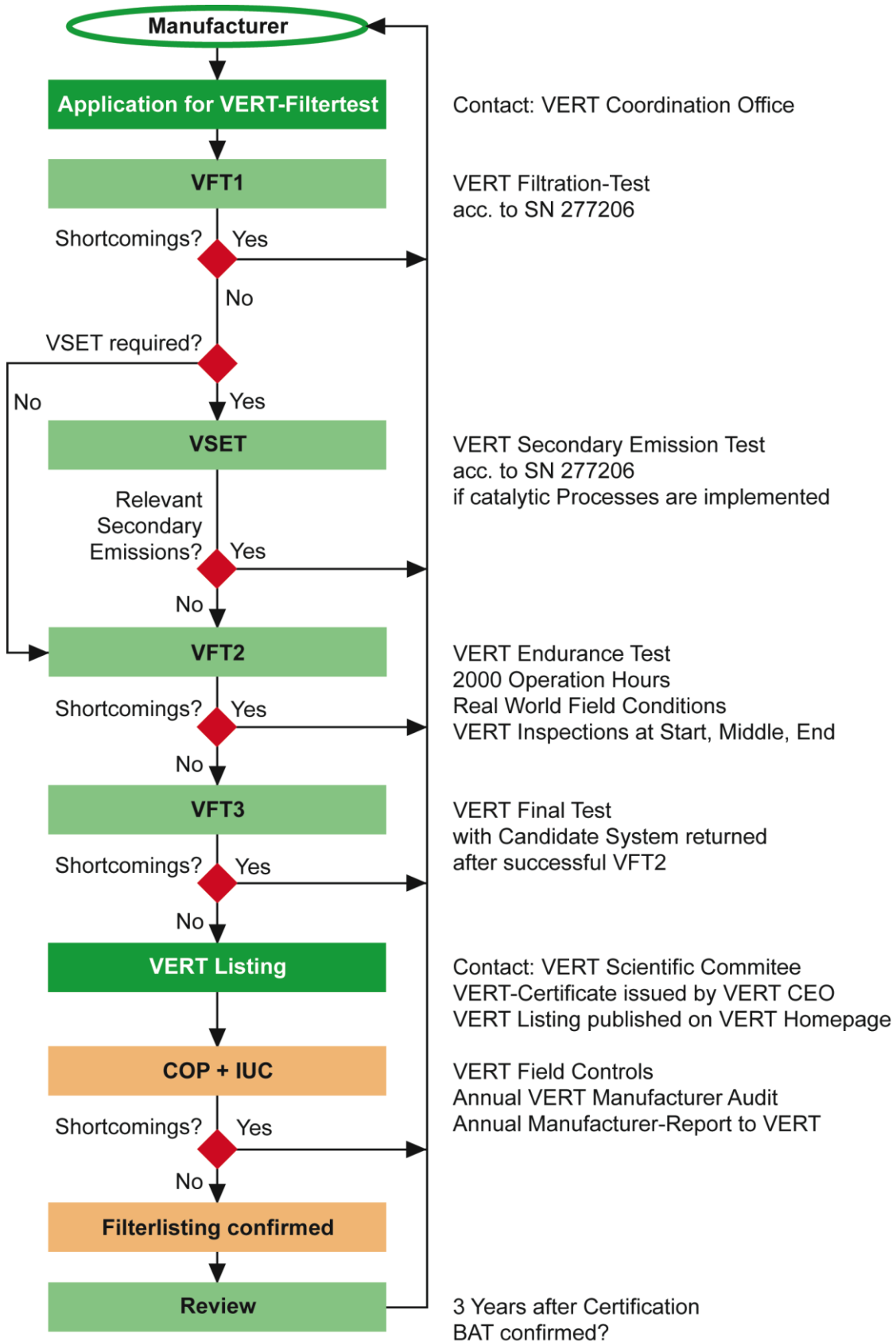

1.1. Particle filter systems for retrofitting

The VERT[®] tests are performed, according to the above scheme, on all PFS systems and components intended for retrofitting. Retrofitting is defined as fitting PFS to vehicles and equipment, which were type-tested without particle filters. Irrelevant is whether the retrofitting is done in the factory, at the vendor, by a retrofitting company or by the operators themselves. Also irrelevant is whether the engine is new or has been deployed for a long time.

Enrolment in the VERT filter list is only possible after successful completion of the full VERT test, consisting of VFT1 + VSET (if applicable) + VFT2 + VFT3 according to SN277206, check of conformity with VERT-rules and final examination of the results by the VERT scientific committee.

A similar procedure is performed for combined VERTdePN-systems, consisting of filters and NOx-reduction catalysts [13, 14]. They must successfully complete VPNT1, VPNT2, VPNT3 and VPNSSET.

When retrofitted each system must perform a so-called VERT acceptance test and a respective protocol (see appendix) must be completed and signed by vendor and buyer – see Appendix.

1.2. Particle filter systems as original equipment

Alternatively, if the PFS is not tested as an individual component for retrofitting new or older Diesel engines, instead, the engine (vehicle) manufacturers themselves engineer the system component for original equipment or as integrated equipment, then the assumption is that the engine (vehicle) manufacturer performs meticulous and prolonged testing. Moreover, the manufacturers themselves ensure integration, guarantee filter/engine compatibility and provide the electronic monitoring of the entire system.

In this case too enrolment is only possible after successful completion of the VERT[®] test. When catalyst coatings or FBC are used, the secondary emission test VSET must be passed. Subsequently, the emission stability must be demonstrated during 2,000 hours deployment. For this purpose the certifying lab must seal the PFS in order to prevent tampering during probationary deployment. However all tests can be performed on the manufacturers test rigs, according to the European certification Directive 97/68/EC. The VFT2 test can be done on the test rig as well within the scope of the European Directive 2004/26/EC on emission deterioration factors.

1.3. Re-certification after technical alterations

The PFS manufacturer must communicate all intended alterations of an enrolled PFS of component to the VERT[®] coordination office. The VERT[®] coordinator then decides which tests ought to be repeated.

The basic rules are as follows:

- If main components are altered, which impact the PFS filtration characteristics, then the entire test sequence VFT1–3 must be repeated.
- If catalytic components are altered, then the VSET must be repeated.
- If functional elements of the mechanical/electrical auxiliaries are altered, which could impact operational durability, then the VFT2 (deployment during 2,000 operating hours) and concluding VFT3 must be repeated.
- Minor alterations can be administratively approved.

1.4. Approval of filter media

For the VERT[®] testing of filter media, VFT1 test is sufficient, provided the filter media are not catalytic coated. Catalytic coated media must also pass the VSET secondary emissions test.

1.5. Approval of regeneration additives

Mandatory is VFT1 plus VSET secondary emission test including a size-specific metal analysis of the emissions. Moreover, the additive must comply with valid European Directives on safety and environmental compatibility.

Further aspects with respect to the additive dosing system, safety on board and monitoring are comprehensively defined in the VERT FBC-System Specification [7].

1.6. Approval of OBM units

All filter systems (except filters for short duration use – so called snap-on-filters) must have on-board electronic monitoring OBM of back pressure and temperature. The prerequisites for approval are conformity inspection and endurance test according to the VERT OBM-System-Specification [8]. Endurance test shall be combined with a VFT2 filter test during at least 2000 hours of operation with subsequent functional verification.

Filters for short duration use, which cannot be regenerated, only need a pressure indicator which might be mechanic or electronic. Recommended are peak-storing instruments.

1.7. Verification of conformity after 3 years

At latest 3 years after granting VERT[®] certification, the PFS must be re-certified proving conformity with the prevalent BAT and Directives. If the PFS does not comply, then the manufacturer has 1-year time to improve the PFS. Compliance must be established by partial or complete retesting of the PFS.

Compliance verification can be confined to a “review”, if field experience and technical data indicate successful operation and conformity with the then valid BAT.

Otherwise, supplementary tests can be requested.

1.8. PFS manufacturers' responsibility

First enrolment in the VERT[®] filter list is based on passing the VERT[®] suitability tests.

To remain enrolled the named PFS manufacturer must identify all delivered PFS with the VERT[®]-label and perform the VERT[®] acceptance tests and accept responsibility for the quality of all PFS delivered to correspond to the tested and approved technology and to be fitted and maintained in accordance with the VERT[®] rules. Furthermore the manufacturer must prove on an annual basis that failure rate in the field of each of his filter families does remain below 5 % for all filters not older than 5 years.

1.9. Non-transferability of the VERT[®] certificate

The VERT[®] certificate is issued to a named PFS manufacturer. The PFS manufacturer cannot reassign the VERT[®] certificate to another manufacturer, or to the manufacturer's vendors and sales agents.

2. VERT[®] PFS - Approval Criteria

2.1. Curtailing particle emissions by Particle count PC

- Filtration rate for solid particle number PCFE as defined by UN-ECE PMP according to EC-regulation 715/2007 [10], must be attained in average of all operating points, throughout the particle size range 20-300 nm.

From year	A	B	C
	2000	2007	2016
New state	≥95%	≥97%	≥98%
2000 hrs.	≥90%	≥97%	≥98%

- PCFE during regeneration the criterion is the ratio of averaged values during the whole regeneration process as specified by SN-277206
Regeneration time < 3 % operation time

From year	1 2010	2 2012	3 2016
New state	≥ 60%	≥ 70%	≥80%
2000 hrs.	≥ 60%	≥ 70%	≥80%

- Overall PN-peak reduction during free acceleration ≥ 95%
The criterion is the ratio of the peak values
Measurement as specified by SN 277206

2.2. Legislated emission limits

Compared to the baseline engine values, no increase of the limited emissions CO, HC, NO_x and PM is permissible in the test cycle weighed average. During filter regeneration limited emissions shall not be higher than engine baseline emissions.

2.3. Secondary emissions

Secondary emissions are all compounds which were not present in significant concentrations in the exhaust gas of the base engine before retrofit. Formation of relevant amounts of such toxic reaction products is not permitted following [12, 13].

Compared to baseline engine values, no relevant increase of the following toxic emission components is permissible in the treated exhaust gas after the PFS:

- Gaseous secondary emissions: principally NO₂, Dioxins and Furans, PAH and Nitro-PAH
- Aerosols of sulfuric acids
- Metal oxides (e.g. ash particles from additives, engine wear, lube oil additive packages)
- Mineral fibre emissions in the WHO defined size range L<3 μm; D<5 μm
- Limit Values for NO₂

Average NO₂ increase over engines baseline due to catalytic conversion of engine-out NO shall not exceed 20 % in relation to NO upstream filter for all systems certified from 2016. This value shall be determined as per SN 277206 .

A	B
until year 2015	from year 2016
No limit	ΔNO ₂ /NO<20%

- Filter systems converting engine-out NO into NO₂ can only be used in environments where the concentration of NO₂ in ambient air is well below the locally valid air quality limits.

Relevance of other secondary emissions

Increase of trace substances like Dioxins, Furans, PAH, Nitro-PAH and metal oxide particles < 400 nm are deemed “relevant” when the exhaust gas after the PFS exhibits concentrations, exceeding thrice the engine emission (statistically significant) without PFS, at the same operating points

2.4. Pressure loss

- Fresh filter: < 50 mbar at high idle
- Regeneration threshold: < 150 mbar
- Maximum soot + ash burden: < 200 mbar (95% percentile)
- Alarm episodes > 5 sec above 200 mbar
- Special cases: If tolerated by the operator and the engine manufacturer, a pressure loss of maximum 300 mbar can be accepted at maximum soot+ash burden. Engines with uncontrolled EGR shall not be operated against more than 120 mbar back-pressure, the permissible level might be even lower and must be agreed upon by the engine manufacturer and the operator.

2.5. Additive dosage

Automatic with interrupt if filter ruptures.

See VERT FBC-System specifications [7].

2.6. Function monitoring OBD

See VERT OBC-System specifications [8]

- Continuous electronic monitoring of backpressure and exhaust temperature
- Measurement every second, storage on 1 minute base
- Alarm signal and alarm logging when maximum back-pressure is exceeded.
- Additive (if used): dosage shut off automatically when filter damage is detected.
- Special situations: For PFS which are externally regenerated or replaced for regeneration as well as for temporary filters (so-called snap-on filters), the electronic monitoring can be substituted. Permitted is instead a simple pressure gauge with visual or acoustic alarm.
- In case the operator does not properly react to the alarms, the OBD-system shall activate an automatic safety feature, which might be torque reduction, re-start limitation or even engine shut-off.

2.7. Noise Attenuation

Attenuation must be at least equivalent to the muffler replaced. For comparison near field measurement is specified [11].

2.8. Durability, Maintenance and Warranty

- Life expectancy > 5000 operation hours
- Usable hours until cleaning > 2000 operation hours
- Maintenance interval > 500 operation hours
- Guarantee on materials and function > 2 years or 1000 op. hours (whichever is earlier)

2.9. Labeling

Main and auxiliary components of the PFS must carry an identification plate in a manner that is durable, unambiguous and legible. This is necessary to determine the filter family clearly in a unique manner and must also contain at least the certification identity, serial number, manufacturing data for quality control and the flow direction. The information on this plate must be identical with the certification data in the VERT[®] filter list; especially the certification identity. In addition each vehicle retrofitted with VERT[®] approved PFS shall carry a green VERT[®] label with an individual running number to be identified for the VERT[®] data base.

2.10. Flow direction

Flow direction through the PFS must be indicated clearly with an arrow see 2.9. Moreover, unidirectional design must prevent reversed mounting of the filter element.

2.11. Safety

The PFS must be mounted according to the manufacturer's instructions such that no additional risks occur. The assembly must comply with the legislation on health, safety and visibility in the country where the PFS is deployed. Surface temperature requirements must be respected. Heat shielding is recommended and spark arrestors shall be used whenever the filter is operated under fire risk environmental conditions e.g. in forests or indoors.

2.12. Bypass

Bypass arrangements, which permit circumventing the filter during excess back-pressure, are generally impermissible. Both manual and automatic bypass are prohibited.

2.13. Diagnosis access

Access to the mounted PFS is required to measure the raw emissions for engine diagnosis and to determine the filtration efficiency in situ if requested. For this purpose, the filter casing or exhaust pipe must have, upstream of the filter element, a diagnose access of minimum 40 mm inner diameter [11] if opacity is to be measured and >8mm inner diameter if PN and gases are to be measured.

2.14. Cleaning and disposal

The filter element requires periodic cleaning from ash residues and the element must be eventually disposed off. Only methods that are environmentally acceptable, manufacturer approved and declared in the application documents for the suitability test shall be used for cleaning and disposal. The trapped residues are toxic waste. These must be carefully collected and, if in small quantities, disposed together with other industrial waste in a waste incinerator. The local authorities decide how larger quantities shall be disposed. Workers must be protected from exposure to fine dust during cleaning and disposal.

2.15. Substituting mufflers for PFS

Employing so-called muffler modules instead of PFS (e.g. during PFS maintenance or filter cleaning) is only permissible with the approval of the regulatory authorities. The only permitted muffler modules are those that are tested during the VERT[®] certification, described in the test reports and clearly identified as such.

2.16. Technical reporting the retrofit

An installation report must be prepared for each retrofit and signed by the retrofitter and the vehicle owner. See appendix VERT-acceptances test report and www.vsbm.ch. The retrofitted vehicle or equipment must display a VERT[®] Label with an individual running number, see Appendix. The installation report must be submitted to the VERT[®] coordination office for registration in the VERT[®] database.

2.17. COP = Conformity of Production

Responsibility of the manufacturers and subject to an annual VERT® audit procedure. The rules, for manufacturing quality control, are still to be defined.

2.18. IUC = In Use Compliance Tests

Responsibility of the manufacturers and subject to an annual VERT® audit procedure. The rules for periodic field testing of the PFS, are still to be defined.

2.19. Operation Manual

Each filter retrofitted must be accompanied by an operation manual in the language of the country where the filter is used. This manual must contain all information on functional, maintenance and safety issues, cleaning procedures and responsibility statements.

2.20. Impact on Energy Consumption

The overall energy impact of the PFS including all effects of back pressure and regeneration integrated over the life cycle must remain below 3 %.

2.21. Criteria for VERTdePN-Systems in addition to 2.1-2.20

- NOx - Reduction
-
-
- NH₃-emission < 25 ppm
- N₂O-emission < 10 ppm
-

	A	B	C
New state	≥85%	≥75%	≥65%
1000 hrs.	≥75%	≥65%	≥55%

3. VERT[®] List of approved systems and components

3.1. Particle filter systems for prolonged deployment

MANUFACTURER PFS Type: PFS family F: Filter medium R1: Regeneration method 1 K: Electronic monitoring unit	Suitability test				Status		Certificate	
	VFT1	VFT2	VFT3	VSET	PCFE see 2.1	NO ₂ see 2.3	Number	Date
AGD PFS Type: DIS F: CORNING DuraTrap [®] CO R: Catalytic Coating K: PDL.V3.3	B106/05.02	B196/12.06	B196/12.06	B114/03.03	C	A	B196/12.06	18.03.2010
AIRMEEX PFS Type: CARMEX SC F: IBIDEN SiC wallflow filter R1: FBC satacen (Fe) R2: FBC satacen 3 (Fe) K: AIRMEEX DTL 3600	B148/08.04	B171/11.05	B171/11.05	B043/09.97	C	B B	B171/11.05	18.03.2010
AIRMEEX PFS Type: CARMEX CSC F: CORNING DuraTrap [®] CO R: Catalytic Coating K: AIRMEEX DTL 3600	B206/09.07	B280/03.10	B280/03.10	B233/05.08	C	A	B280/03.10	22.07.2010
ASEC PFS Type: STARFILTER F: SiC cell filter R: Cat.Coat.with Recuperation K: Dyntest	B225/06.08	B281/05.10	B282/05.10	B282/06.10	C	B	B281/05.10	22.07.2010 30.03.2016
BAUMOT PFS Type: BAB/BA F1: CORNING DuraTrap [®] CO F2: NGK DHC-558 Cordierite R: Catalytic coating K: DYNTEST AML V3.0	B210/12.07	B219/05.08	B219/05.08	B215/04.08	C	A	B219/05.08 B432/02.16	18.03.2010 30.03.2016
BERSY PFS Type: BPF-DOC F: Liqtech SiC cell filter R: CAM-FBC / satacen [®] K: Pirelli Ambiente	B165a/00.05	B199a/04.07	B199a/04.07	B179a/04.06	C	A	B199a/04.07	18.03.2010

	Suitability test				Status		Certificate	
	VFT1	VFT2	VFT3	VSET	PCFE see 2.1	NO ₂ see 2.3	Number	Date
MANUFACTURER PFS Type: PFS family F: Filter medium R1: Regeneration method 1 K: Electronic monitoring unit								
BERSY PFS Type: BPF F: Liqtech SiC cell filter R: CAM-FBC (Fe) / satacen ® K: Pirelli Ambiente	B165a/00.05	B200a/04.07	B200a/04.07	B179a/04.06	C	B	B200a/04.07	18.03.2010
CDTi PFS Type: PURIFILTER® F: SiC: Ividen, Pirelli, Liqtec R: Catalytic Coating Pt K: DYNTTEST AML V3.0	B132/04.03	B133/04.03	B133/04.03	B138/09.03	B	A	B133/04.03	10.04.2014
CDTi PFS Type: Combifilter® Type V F: Corning Dura TrapTMCO R1: Electric in situ at standstill R2: Exchange Filter K: DYNTTEST AML V3.0	B021/12.05	B049/05.98	B049/05.98	-----	A	B B	B049/05.98	10.04.2014
CDTi PFS Type: Combifilter® Type K18 F: SiC IBIDEN, Pirelli, Liqtec R1: Electric in situ at standstill R2: Exchange Filter K: DYNTTEST AML V3.0	B118/11.02	B118/11.02	B118/11.02	-----	A	B B	B118/11.02	10.04.2014
CDTi PFS Type: Purifilter EGR F1: Liqtech SiC wallflow 150 cpsi F2: Pirelli SiC wallflow 150 cpsi R: Cattalytic Coating + Pre-Cat K: DYNTTEST AML V3.0	B236/09.08	B410/04.15	B410/04.15	B404/11.14	A	B	B410/04.15	28.06.2015 09.11.2015
DAUGBJERG A/S PFS-Type: SCAN-Filter F: Liqtech Sic cell filter R: FBC Pt Plus DFX (Ce, Pt) K: Daugbjerg PF-101-3000	B140a/12.03	B211/02.08	B211/02.08	B083/11.00	C	B	B211/02.08	10.10.2010
DCL PFS Type: MINE-X SOOTFILTER F: CORNING DuraTrap® CO R: Catalytic Coating K: DYNTTEST AML V.3.0	B129/04.03	B230/08.08	B230/08.08	B231/07.08	C	A	B230/08.08	18.03.2010
DCL PFS Type: Titan™ and BlueSky™ F: IBIDEN SiC cell filter R1: Replace Filter R2: Electrical in-situ standstill R3: FBC satacen 3; EOLYS (Ce) K: DCL AF01	B078/07.00	B125/02.03	B125/02.03	B043/09.97	C	B B B	B125/02.03	18.03.2010

	Suitability test				Status		Certificate	
	VFT1	VFT2	VFT3	VSET	PCFE see 2.1	NO ₂ see 2.3	Number	Date
MANUFACTURER PFS Type: PFS family F: Filter medium R1: Regeneration method 1 K: Electronic monitoring unit								
DINEX PFS Type: DIPEX (DPX1 and DPX2) F: CORNING DuraTrap® CO R1: Cat. Coating = BASF DPX1 R2: Cat.Coating. = BASF DPX2 K: DinLog, Dyntest	B106/05.02	B160/03.05	B160/03.05	B114.04/03	C	A A	B160/03.05	18.03.2010
DINEX PFS Type: DiSiC catalysed F: DINEX DiSiC cell filter R1: Cat. Coating Dinex X25 K: DinLog, Dyntest	B220/05.08	B269/11.09	B269/09.09	B232/08.08	C	A A	B269/09.09	18.03.2010
EHC PFS.Type: EHC PF F: LiqTech SiC cell filter R: Catalytic Coating K: DYNTEST AML V3.0	B235/09.08	B289/08.10	B289/08.10	B264/08.09	C	A	B289/08.10	10.10.2010
ELRINGKLINGER PFS Type DIS F: SiC HUG 100 cpsi R: Catalytic coating+HC-dosing K: DYNTEST AML V3.0	B216/06.08	B351/02.13	B351/02.13	B229.07.08	C	B	B351/02.13	10.04.2014
EMINOX PFS Type: DPF-CRT™ F1: CORNING DuraTrap® CO F2: Cats & Pipes Cordierite R1: Catalytic Coating K: Eminox ESI	B112/10.02	B180/05.06	B180/05.06	B113/10.02	C	A	B180/05.06 B384/07.14	18.03.2010 15.08.2014
EMINOX PFS Type: DPF-FBC F: LiqTech SiC cell filter R1: FBC satacen 3 (Fe) K: Eminox REBE0156	B140/11.03	B167/10.05	B167/10.05	B043/09.97	C	B	B167/10.05	18.03.2010
F2 EMINOX PFS Type: DPF-FBC active F: LiqTech SiC cell filter R1: FBC satacen 3 (Fe) R2: on board electric K: Eminox REBE0156	B140/11.03	B244/12.08	B244/12.08	B043/09.97	C	B B	B244/12.08	18.03.2010

	Suitability test				Status		Certificate	
	VFT1	VFT2	VFT3	VSET	PCFE see 2.1	NO ₂ see 2.3	Number	Date
MANUFACTURER PFS Type: PFS family F: Filter medium R1: Regeneration method 1 K: Electronic monitoring unit								
EXOCLEAN PFS Type: EXOCLEAN F: Iridium SiC cell filter R1: Catalyst fuel combustion R2: FBC: EOLYS (Ce/Fe) K: SITA MOS	B147/07.04	B153/03.05	B153/03.05	B156/03.05	C	A B	B153/03.05	18.03.2010
HJS PFS Type: SMF [®] -AR F: HJS Sintered Metal Filter R1: active FBC satacen [®] 1 active FBC satacen [®] 2 active FBC satacen [®] 3(plus) R2: active FBC Solvay Eolys K: HJS-ECU V1.36; E13 03 10203	B155/04.05	B195/12.06	B195/12.06	B043/09.97 EMPA 167985	C	B B	B195/12.06	18.03.2010
HJS PFS Type: SMF [®] -FBC F: HJS Sintermetall Filter R1: passive FBC satacen [®] 1 passive FBC satacen [®] 2 passive FBCsatacen [®] 3(plus) R2: passive FBC Solvay Eolys K: V1.43se; E13 039918	B021/02.95	B049/5.98	B049/5.98	B043/09.97 EMPA 167985	C	B B	B049/5.98	18.03.2010
HJS PFS Type: CRT [®] F: CORNING DuraTrap [®] CO R: Cat, Coating K: V1.43se; E13 039918	B053/4.98	B097/10.01	B097/10.01	B111/10.02	C	A	B097/10.01	18.03.2010
HJS PFS Type: SMF [®] -CRT [®] F: HJS-Sintermetall Filter R: Catalytic Coating K: V1.43se; E13 039918	B155/03.05	B159/03.05	B159/03.05	B111/10.02	B	A	B159/03.05	18.03.2010
HJS PFS Type: SMF [®] -ER F: SMF Sintermetall Filter R: Off-line thermic or mechanic K: Manometer with peak value storage							B155/04.05	25.09.2015

	Suitability test				Status		Certificate	
	VFT1	VFT2	VFT3	VSET	PCFE see 2.1	NO ₂ see 2.3	Number	Date
MANUFACTURER PFS Type: PFS family F: Filter medium R1: Regeneration method 1 K: Electronic monitoring unit								
HUG PFS Type: mobiclean S (nauticlean; combikat) PF: HUG SiC cell filter R1: Cat.Coating (base metal) R2: Cat.Coating (precious metal) R3: Diesel burner K1 HUG integrated with burner K2 DYNTTEST AML V3.0	B216/06.08	R3: B168/08.05 R1.2: B227/07.08	R3: B168/08.05 R1.2: B227/07.08	R1: B157/04.04 R2: B229/07.08	C	B A B	R3: B168/08.05 R1.2: B227/07.08	18.03.2010
HUG PFS Type: mobiclean R PF: HUG SiC cell filter R1: Cat.Coating (base metal) R2: Cat.Coating (precious metal) R3: Diesel burner K1: HUG integrated with burner K2 DYNTTEST AML V3.0	B216/06.08	R3: B168/08.05 R1.2: B228/07.08	R3: B168/08.05 R1.2: B228/07.08	R1: B157/04.04 R2: B229/07.08	C	B A B	R3: B168/08.05 R1.2: B228/07.08	18.03.2010
HUG PFS Type: mobiru F: Fiber woven filter system R: Diesel idle burner K: HUG integrated with burner	B099/11.01 only stationary application				A	B	B099/11.01	18.03.2010
HUSS PFS Type: MA-Serie F: IBIDEN or CDC SiC R: FBC satacen 3 (Fe) K: HUSS integrated	B105/04.02	B203/05.07	B203/05.07	B043/09.97	C	B	B203/05.07	18.03.2010
HUSS PFS Type: SK or W F: IBIDEN or CDC SiC R1: Electrical at standstill R2: Replace Filter K: HUSS ECU	B105/4.02	B105/4.02	B105/4.02	-----	C	B B	B105/4.02	18.03.2010
HUSS PFS Type: MK F: IBIDEN or CDC SiC R: Diesel burner at standstill K: HUSS integrated	B109/7.02	B131/4.03	B131/4.03	-----	C	B	B131/4.03	18.03.2010

	Suitability test				Status		Certificate	
	VFT1	VFT2	VFT3	VSET	PCFE see 2.1	NO ₂ see 2.3	Number	Date
MANUFACTURER PFS Type: PFS family F: Filter medium R1: Regeneration method 1 K: Electronic monitoring unit								
HUSS PFS Type: ME F: IBIDEN or CDC SiC R: Electrical at standstill K: HUSS integrated	B105/04.02	B188/09.06	B188/09.06	-----	C	B	B188/09.06	18.03.2010
HUSS PFS Type: MD F: IBIDEN or CDC SiC R: Catalytic fuel combustion K: HUSS ECU	B212/02.08	B274/01.10	B274/01.10	B233/08.08	C	B	B274/01.10	18.03.2010
HUSS PFS-Type MC F: CDC SiC cell filter R: Catalytic coating, passive K: HUSS Datlogger	B245/12.08	B343/11.12	B343/11.12	B265/08.09	C	B	B343/11.12	10.04.2014
INTECO PFS Type: ECOPUR K xx yy F: Metal fiber fleece R: FBC satacen 3 K: INTECO	B082/10.00	B124/02.03	B124/02.03	B043/09.97	B	B	B124/02.03	18.03.2010
JOHNSON MATTHEY PFS-Type DPFi/DPFis/DPF-CRT® CCRT® / CSF F: NGK Cordierit 200 cpsi R1: DOC / Cat. Coating R2 : Electric at Standstill R3: FBC satacen (Fe) R4: FBC EOLYS (Ce) K: PIO-CAN	B328/02.12	B090/04.01	B090/04.01	EMPA 167985	C	A B B B	B090/04.01-03.12 B443/12.15	02.04.2012 15.12.2015
KRONE PFS Type Krone DPF SMF®-MR F: Filter Metal Substrate R: Offline Regeneration K: Peak pressure manometer	B415/05.15						B415/05.15	28.06.2015
LIEBHERR PFS Type: LH DPF System R01 F: CORNING DuraTrap® CO100 R: Cat. Coating = BASF K: OBD Liebherr Data Logger	B136/09.02	B192/11.06	B192/11.06	B137/09.03	C	A	B192/11.06	18.03.2010

	Suitability test				Status		Certificate	
	VFT1	VFT2	VFT3	VSET	PCFE see 2.1	NO ₂ see 2.3	Number	Date
MANUFACTURER PFS Type: PFS family F: Filter medium R1: Regeneration method 1 K: Electronic monitoring unit	VFT1	VFT2	VFT3	VSET	PCFE see 2.1	NO ₂ see 2.3	Number	Date
LIEBHERR PFS Type: LH DPF System R02 F1: CORNING DuraTrap® AC-200 F2: NGK DHC-558-200 R: Catalytic Coating BASF K: OBD: Liebherr Data logger	B314/09.11 B328/02.12	B336/08.12	B336/08.12	B137/09.03			B336/08.12	14.01.2013
LINDE-STILL-EBERSPAECHER PFS Type: ZSB F: NGK Cordierite R: Diesel burner at standstill K: integrated	B273/03.10	B275/03.10	B275/03.10	-----	B	B	B275/03.10	18.03.2010
PHYSITRON PFS Type: DPX1 F: CORNING DuraTrap® CO R: Catalytic Coating K: DYNTTEST AML V3.0	B106/05.02	B123/02.03	B123/02.03	B114/04.03	C	A	B123/02.03	01.08.2014
PHYSITRON PFS Type: DPX2 F: CORNING DuraTrap® CO R: Catalytic Coating K: DYNTTEST AML V3.0	B106/05.02	B136/09.03	B136/09.03	B137/09.03	C	A	B136/09.03	01.08.2014
PHYSITRON PFS Type: Physitec SiC-B; SiC-CB F: Ividen-SiC; Liqtech SiC R1: Diesel burner at standstill R2: Catalytic Coating K: DNY / MultiControlBox	B132/04.03	B270/11.09	B270/11.09	B138/09.03	C	B	B270/11.09	18.03.2010
PIRELLI PFS Type: FeelPure-DOC F: Pirelli & C.Eco Techn. R: CAM-FBC (Fe) K: Pirelli & C.Eco Techn.	B165/09.05	B199/04.07	B199/04.07	B179/04.06	C	A	B199/04.07	18.03.2010
PIRELLI PFS Type: FeelPure F: Pirelli & C.Eco Techn. R: CAM-FBC (Fe) K: Pirelli & C.Eco Techn.	B165/09.05	B200/04.07	B200/04.07	B179/04.06	C	B	B200/04.07	18.03.2010

	Suitability test				Status		Certificate	
	VFT1	VFT2	VFT3	VSET	PCFE see 2.1	NO ₂ see 2.3	Number	Date
MANUFACTURER PFS Type: PFS family F: Filter medium R1: Regeneration method 1 K: Electronic monitoring unit	VFT1	VFT2	VFT3	VSET	PCFE see 2.1	NO ₂ see 2.3	Number	Date
PIRELLI PFS Type: FeelPure AR F: Pirelli & C.Eco Techn. R: CAM-FBC (Fe) K: Pirelli & C.Eco Techn.	B165/09.05	B279/03.10	B279/03.10	B179/04.06	C	B	B279/03.10	18.03.2010
PROVENTIA PFS Type: PROAIR DFPF FB F: Liqtech SiC cell filter R: FBC satacen 3 (Fe) K: Dyntest	B140a/12.03	B267/10.09	B267/10.09	B043/09.97	C	B	B267/10.09	18.03.2010
PURltech PFS Type: DAS-DBS F: NOTOX-SiC; LIQTEC-SiC R1: Catalytic combustion R2: FBC satacen 3 (Fe) K: PURltech Zentraleinheit	B224/06.08	B278/03.10	B278/03.10	B217/04.08	C	B	B278/03.10	18.03.2010
PURltech PFS Type: DPF-1/2, DPFN, DPFN+ F: Cordierite, 200 cpsi R1: Catalytic Coating K: PURltech Zentraleinheit	B314/09.11	B322/02.12	B322/02.12	B323/02.12	C	B	B322/02.12	01.03.2012
TEHAG PFS Type: CWF F: CORNING DuraTrap® CO R: Catalytic Coating K: Dyntest	B222/06.08	B254/02.09	B254/02.09	B246/12.08	C	B	B254/02.09	18.03.2010

3.2. On-board monitoring (OBM)

MANUFACTURER Type	Suitability test	Certificate	
	Number	Number	Date
CPK AUTOMOTIVE Electronic DPF Monitor & Control Dyntest V.4	B313	B313/06.11	30.6.2011
DEC De-Tronic	B327	B327/01.12	22.03.2012
ESW Filter-Monitor: MLC 6 Firmware: CS6	B452	B452/04.15	30.04.2016
MANN + HUMMEL ECU No. 1083898S01	B330	B330/03.12	20.03.2012

3.3. Particle filter systems for short duration usage

MANUFACTURER Type F: Filter medium R: Regeneration method K: OBM electronic PFS monitoring	Suitability test	Certificate	
	Number	Number	Date
ARPA-ER-ENDEAVOUR PFS Type: Progetto Blu F: Paper filter cartridge R: Disposal when >200 mbar K: ELIWELL TCJ - OV	B151	B151/02.05	18.03.2010
Baumüller PFS-Type BP 450-8 F: Glass fiber fleece R: Disposal as industrial waste K: Peak pressure manometer	B407	B407/01.15	28.06.2015
DT PFS Type. TWPF F: Ceramic / wire knit R1: Catalytic coating R2: Hot air blower, external K: Peak pressure manometer	B128a	B128a/07.04	18.03.2010

	Suitability test	Certificate	
EHC PFS Type: HT F: Micro Glass Fiber Media R2: Incineration (ind.waste) R1: Disposal as industrial waste K1: Electric backpress. control K2: Peak pressure manometer	B135 B416	B135/10.03 B416/06.15	18.03.2010 14.12.2015
EHC PFS Type: L20/P15 F: Micro Glass Fiber Media R: Incineration (ind.waste) K: Manual backpress. control	B272	B272/03.00 B416/06.15	18.03.2010
HSE PFS Type: MF 180 / MF 100 F: Pleated Glass Fiber Media R: Incineration (ind. waste) K: Manual backpress. control	B277	B277/03.10	18.03.2010

3.4. Particle filter media

MANUFACTURER F: Filter medium	Suitability test	Certificate	
		Number	Date
CDC-GmbH F: SiC cell filter, 200 cpsi	VFT1 B212	B212/02.08	18.03.2010
CORNING F: CORNING DuraTrap® CO Cordierite cell filter. 100 cpsi	B066	B066/02.00	18.03.2010
CORNING F: CORNING DuraTrap® AC Cordierite cell filter, 200 cpsi	B314	B314/09.11	30.09.2011
HUG F HUG SiC cell filter	B216	B216/04.08	18.03.2010
IBIDEN F1: SiC cell filter F2: SiC cell filter	B062 B070	B062/10.99 B070/03.00	18.03.2010 18.03.2010
KHANCERA F: KDB200N SiC – 200 cpsi	B312	B312/07.11	30.09.2011
LIQTECH F1: SiC cell filter, 90 cpsi F2: SiC cell filter, 150 cpsi	B140a B236	B140a/12.03 B236/09.08	18.03.2010 18.03.2010
NGK F: DHC-558 Cordierite, 200 cpsi	B328	B328/02.12	29.02.2012
SAINT-GOBAIN F: SG3-A1 SiC, 191 cpsi	B293	B293/10.11	22.11.2011

3.5. Regeneration additive (FBC)

	Suitability test	Certificate	
		Number	Date
MANUFACTURER Name of the additive Active substance Maximum dosage	VSET		
CDTi Platinum Plus® DFX-DPF Active substances Ce+Pt Dosage max 7.5 mg Ce + 0.5 mg Pt/kg fuel	B083	B083/10.00	18.03.2010
INFINEUM Infineum F7990 and Infineum F7991 Active substance Fe Dosage max. 25 mg/kg fuel	B101	B101/12.01	18.03.2010
INFINEUM Infineum F7994 and Infineum F7995 Active substance Fe Dosage max. 25 mg/kg fuel	B202	B202/04.07	09.02.2015
INNOSPEC satacen® Dosage max. 25 mg/kg fuel	B043 EMPA 167985	B043/09.97	18.03.2010
INNOSPEC HJS F51 Active substance Fe Dosage max. 36 mg Fe/kg fuel	B043 EMPA 167985	B043/09.97	18.03.2010
INNOSPEC Mann+Hummel DT 7 Active substance Fe Dosage max. 36 mg Fe/kg fuel	B043 EMPA 167985	B043/09.97	18.03.2010
PIRELLI CAM-FBC Active substance Fe Dosage max. 20 mg/kg fuel	B179	B179/04.06	18.03.2010

3.6. Particle filter systems with sales volume < 50 p.a.

	Suitability test				Status		Certificate	
	VFT1	VFT2	VFT3	VSET	PCFE see 2.1	NO ₂ see 2.3	Number	Date
MANUFACTURER PFS Type: PFS family F: Filter medium R1: Regeneration method 1 K: Electronic monitoring unit								

3.7. VERTdePN-Systems: Filtration + NOx-reduction

	Suitability test				Status			Certificate	
	VPNT 1	VPNT 2	VPNT 3	VPNSET	K _{NOx} >75 / 65 / 55 %	NH ₃ <20 / 30 / 40 ppm	N ₂ O <10 / 20 / 30 ppm	Number	Date
MANUFACTURER S: DePN-System or Type: F: Filter substrate N: DeNOx substrate R1: Regeneration method 1 C1: Conversion method K: Electronic monitoring unit									
DINEX S: DiNOx-System F: DiSiC B269/09.09 N: HTAS Cordierite R1: Catalytic Coating C1: Vanadia + Adblue K: DinLog	B213/06.08	B313/08.11	B329/03.12	EMPA 206280/10.08	A	A	A	B329/03.12	22.03.2012

4. Self commitments of VERT® certified Manufacturers & Retrofitters

A. Self-commitment of manufacturers of VERT® certified PFS:

- The PFS manufacturer commits to only sell VERT® certified PFS technology, which is identical with the certified state, as detailed described in his respective VERT® test reports.
- The PFS manufacturer commits to communicate all intended PFS alteration to the VERT® coordination office.
- The PFS manufacturer admits a VERT® Association officer to perform an annual quality audit.
- The PFS manufacturer controls the quality of his products in the field and submits complete information on failures annually to the VERT® coordination office.

B. Self-commitment of enterprises retrofitting VERT® certified PFS:

- Retrofitters must comply with the VERT® rules in this VERT® filter list
- Retrofitters must have a contractual relationship with the certified PFS manufacturer whereas. The PFS manufacturer is finally responsible for malfunction and liable for compensation also when the retrofitter is unable to settle the damage claims.
- Retrofitters must have their own workshop and trained employees to perform all necessary work for PFS installation, maintenance and repairs.
- Retrofitters must have officially calibrated measuring instruments for pressure and temperature control, particle emissions and noise emission,
- Retrofitters are capable of commissioning and of functional inspection of the PFS, compliant with all specifications and directives.
- Retrofitters shall enter into delivery contracts with their customers, promptly document all technical data, and grant their customers the VERT® specified guarantee for materials and function during at least 2 years.
- Retrofitters shall accept responsibility for damages consequent to PFS retrofitting. They are explicitly responsible for engine damage proven due to sustained back-pressure exceeding 200 mbar, provided the operator has done all necessary maintenance and did not ignore the alarms.
- Retrofitters shall document all retrofits on the one-page VERT® installation report, and send a copy of each such documents to the VERT® coordination office.
- Retrofitters shall affix the pertinent VERT® quality label with their company identification and a running VERT® control number on each retrofitted machines.
- Retrofitters shall report all failures to their PFS suppliers.
- Retrofitters shall participate once a year at VERT® filter technology fresh-up course and delegate all employees who are actually doing the retrofit job to such a course.
- Retrofitters and manufacturers shall clearly identify VERT® certified products in their leaflets, sales communication and exhibition documents using the worldwide protected trademarks VERT®, VERT-DPF®, VERT-certified®, whichever applies best.

5. Recognition of the VERT[®] filter list

The following organizations recognize the quality of VERT[®] tested PFS; some (*) require VERT-certification expressis verbis in their legal documents, listed either in this VERT Filterlist or in the BAFU-Filterlist

- Austria: AUVA*, Tyrol, Vienna
- Canada: DEEP*
- Chile: MMT*
- China: VECC*, BJ-EPB*
- Colombia: SDA Bogotá*
- Denmark: DTI
- England: LEZ London
- France: CRAMIF*, INRS
- Germany: BG BAU, UBA, TRGS* Berlin
- Hongkong: KBM, NWFB*
- Iran: AQCC Tehran, DOE*
- Israel IMEP*
- Italy: South Tyrol
- Netherlands: VROM
- New York: City* + Port*
- Switzerland: BAFU*, SUVA*, ASTRA*
- USA: CARB, MSHA*

6. VERT[®] accredited test centers

Generally PFS test reports are only accepted from the below listed VERT[®]-accredited test centres. Accreditation acc. to ISO/IEC 17025 ext. SN 277206 is a prerequisite. Those test results are the basis for granting PFS certification according to the VERT[®] criteria. Additional supporting data can be submitted with the request for enrolment in the VERT[®] filter list. Such evidence will be considered in deciding VERT[®] approval.

- AFHB, Laboratory for Exhaust Emissions Control,
University of Applied Sc.BFH-TI Biel, Switzerland
Prof. Dr. J. Czerwinski
Gwerdstrasse 5
CH-2560 Nidau, Switzerland
- EMPA Dübendorf
Dr. N.V. Heeb
Überlandstrasse 121
CH-8600 Dübendorf, Switzerland
- AVL MTC Motortestcenter AB for VFT1
Sten Boman
Armaturvägen
P.O.Box 223
SE-136 23 Haninge, Sweden
- Southwest Research Institute for VFT1
Dr.Imad A.Khalek
6220 Culebra Road
San Antonio, TX 78238, U.S.A
- TÜV Technische Überwachung Hessen GmbH for VFT1, VFT2, VFT3
Karsten Mathies
Werner-von-Siemens-Strasse 35
D – 64319 Pfungstadt

7. Obtaining the VERT® certificate for manufacturing PFS

The PFS manufacturer should first contact an accredited test centre, or the VERT® coordination office, and get information and advice. VERT coordination office can guide him through the process.

After successfully completing all necessary tests, the manufacturer shall submit the test reports to the VERT® coordination office. The application must be accompanied by a duly signed pledge to accept all self-commitments resulting from enrolment in the VERT® filter list.

The VERT® Scientific-Committee will scrutinize the request for enrolment in the VERT® filter list. After a unanimous decision of the 3-member VERT® Committee, a VERT® certificate will be issued. That is the basis for enrolment in the next update of the VERT® filter list.

The VERT® Scientific-Committee can demand additional testing of the PFS or its components. Possible reasons are: data inconsistencies and excessive scatter, suspected PFS deficiencies, emissions of previously unlisted toxins, discrepancies before and after durability testing, etc.

The same procedure is applicable when the VERT® certificate must be revised due to PFS functional or design alterations.

At latest 3 years after issuing the VERT® certificate, the VERT® Scientific-Committee must review the PFS quality, according to the same valid criteria. They can demand PFS improvements if the VERT® criteria have been modified since reflecting improved BAT-level. Those must be completed within 1 year for the PFS to remain on the VERT® filter list. Compliance verification can be confined to a “review”, if the available or new technical data indicate conformity with the then valid criteria. Otherwise, supplementary testing can be demanded.

8. Address list

Filter Manufacturer	Address	Telephone Fax Email
AIRMEEX	AIRMEEX S.A. H.Caliskan 6, rue de l'ancienne Sablière Z.I.de la Fosse Montalbot F – 91270 Vigneux	+33 (1) 69 52 96 01 +33 (1) 69 52 31 30 hcaliskan@airmeex.com
ARPA-ER- ENDEAVOUR	ENDEAVOUR Ricerca e Svipuppo A. Colamussi Corso Giovecca, 144 I – 44121 Ferrara	+39 (0532) 879 603 +39 (0532) 866 381 arturo.colamussi@tin.it scoppi@arpa.emr.it
ASEC	ASEC-DPF Herbert Stieglbauer Am Katzenbuckel 59 D – 82377 Penzberg	+49 8856 80 26 65 Herbert.stieglbauer@gmail.com
BAUMOT	BAUMOT AG Roger Kavena Thurgauerstrasse 105 CH – 8152 Opfikon	+41 (44) 954 8070 +41 (44) 954 34 36 rogerkavena@gmail.com www..baumot.ch
BAUMÜLLER	Baumüller & Partner GmbH J. Baumüller Im Meisental 11 D – 67433 Neustadt	+49 6321 82595 info@baumueller-partner-gmbH.de
BERSY	BERSY SRL Sr. Giorgio Bonaro / Gabriele Arrigoni Via A.Pitentino 24 I – 46010 Levata di Curtatone (MN)	+39 (0376) 290 122 +39 (0376) 478 778 bersy@bersy.it gabriele.arrigoni@bersy.it
CDC	CLEANDIESEL CERAMICS GmbH Christian-Bürkert-Str. 4 D – 01900 Großröhrsdorf	hans-joerg.rembor@hussgroup.com;
CDTi	Clean Diesel Technologies, Inc.(CDTi) Ian MacDonald 83 Commerce Valley Drive East Thornhill, Ontario, Canada L3T7T3	+1 905 431 0410 IMacdonald@cdti.com;
CPK	CPK Automotive GmbH & Co.KG Frank Noack, Sales Director Gildenstrasse 4c D – 48157 Münster	+49 (251) 23948 34 +49 (251) 23948-24 ?? +49 (170) 797 32 68 ?? noack@cpk-automotive.com
CORNING	CORNING Ges.m.b.H. P.Gomez Abraham-Lincoln Str. 30 D – 65189 Wiesbaden	+49 (611) 7366 123 +49 (611) 7366 112 gomezp@corning.com
DAUGBJERG	H.DAUGBJERG A/S Jan Eissensøe Industrivej 20 DK – 2605 Brnømdby	+45(43)96 1545 +45(43)43 1945 jre@scanturbo.dk

Filter Manufacturer	Address	Telephone Fax Email
DCL	DCL International Joe Aleixo P.O.Box 90, Concord Ontario, Canada, L4K 1B2	+1 (905) 660 6450 +1 (905) 660 6435 jaleixo@dcl-inc.com info@dcl-inc.com
DEC	Diesel Emission Control Ltd. David McConochie 36 Lily Close, St. Paul's Court UK – London W14 9YA	+44(20)8741 1005 +44(20)8748 1488 dm@dieselectioncontrol.com; www.dieselectioncontrol.com
DINEX	DINEX A/S Dr. Th. Wolf / O. Gravemann Fynsvej 39 DK – 5500 Middelfart	+49(180)225 1125 OGR@dinex.de tw@dinex.dk
DT	Dieseltechnologie International GmbH S. Kany Hansengelstrasse 4 D – 79801 Hohentengen	+49 (7742) 922 188 +49 (7742) 922 188 Tsh-skany@t-online.de
EHC	EHC TEKNIK ab Ch.J.Granberg Ögärdesvägen 8 SE – 43330 Partille	+46 (31) 44 90 20 +46 (31) 44 49 80 office@ehcteknik.se
ElringKlinger	ElringKlinger AG Matthias Gaepler Warnstedterstrasse 1 D – 06502 Thale	+49 3947 7795 260 Matthias.gaepler@elringklinger.com
EMINOX	EMINOX Ltd Thomas Stanton Miller Road Corringham Road Industrial Estate UK – Gainsborough – DN21 1QB	+44 (1427) 81 16 97 +44 (1427) 81 00 61 thomas.stanton@eminox.com www.eminox.com
ESW	ESW Group Michael Streichsbier, Ph.D. 200 Progress Drive Montgomeryville, PA 18936 USA	+01 510.549.6871 mstreichsbier@eswgroup.com
EXOCLEAN	EXOCLEAN Filtration Technology Annabelle Fayard ZI de la Ponchonnière F – 69210 Saint Bel	+33 (4) 74 01 53 56 +33 (4) 74 01 54 85 +33 6 1291 35 03 (M) Annabelle.fayard@exoclean.com www.exoclean.com
HJS	HJS Fahrzeugtechnik GmbH & Co KG Axel Middendorf Klaus Schrewe Dieselweg 12 D – 58706 Menden	+49 (2373) 3930 200 +49 (2373) 3030 299 Axel.Middendorf@hjs.com Klaus.Schrewe@hjs.com
HSE- EUROROLLER	Health & Safety Engineering Ltd Neil Pattemore Unit 11a, Ascot Industrial Estate Lenton Street Sandiacre, Notts., NG10 5 DJ, U.K.	+44 (870) 421 4206 +44 (870) 421 4207 neil@hse-ltd.com
HUG	HUG Engineering AG Peter Schippers Im Geren 14 CH – 8352 Elsau	+41(52)368 23 72 +41(52)368 20 30 Peter.schippers@hug-eng.ch

HUSS	HUSS Dr. H.-J. Rembor Christian-Bürkert-Strasse 4 D – 01900 Grossröhrsdorf	+49 35952 49790-20 hans-joerg.rembor@hussgroup.com; www.hussgroup.com
IBIDEN	IBIDEN Co.Ltd. Dr. Iris Gege Kitagata, Ibigawa-cho, Ibi-gun Gifu Pref. 501-0695, Japan	+49 (711) 469 186 41 Iris.gege@ibiden.de
INFINEUM	INFINEUM Dr. R. Dallanegra P.O.Box 1, Hilton Hill Business Centre Abingdon UK – Oxfordshire OX13 6BD	+44 (1235) 54 96 40 +44 (1235) 46 93 19 romaeo.dallanegra@infineum.com
INNOSPEC	INNOSPEC Deutschland GmbH W. Kalischewski Ünal Karaagac Thiesstrasse 61 D – 44649 Herne	+49 (2325) 980 281 +49 (2325) 980 289 werner.kalischewski@innospecinc.com uenal.karaagac@innospecinc.com
INTECO	INTECO SA L.Lämmle Chemin des Plantées 24 CH – 1131 Tolochénaz	+41 (21) 801 11 50 +41 (21) 801 45 73 intecosa@bluewin.ch
JOHNSON MATTHEY	Johnson Matthey GmbH & Co KG Peter Werth Otto Volger-Str. 9b D – 65843 Sulzbach/Ts	+49 (6196) 703 812 +49 (6196) 724 50 Peter.werth@matthey.com
LIEBHERR	LIEBHERR Machines Bulle Yves Hohl Rue de l'Industrie 45 CH – 1630 Bulle	+41 (26) 913 3824 +41 (26) 913 3121 yves.hohl@liebherr.com
KHANCERA	KHANCERA Europe Limited Hoil Park 32 Camerley Avenue UK – London SW20 OBQ	+44(0) 825 136320 +44(0) 208 789 4671 +44(0) 208 789 4671 hoilpark@khancera.com
KRONE	Krone Filtertechnik GmbH R. Krone Herbert-Ludwig-Strasse 12-14 D – 28832 Achim	+49 4202-9769-22 rkrone@krone-filter.de www.krone-filter.de
LINDE-STILL- EBERSPÄCHER	J.Eberspächer GmbH & Co KG H.Wahl Eberspächerstrasse 24 D-73730 Esslingen	+49 (711) 939 0206 +49 (711) 939 0222 hermann.wahl@eberspaecher.com
LIQTECH	LiqTech A/S L. Andreassen Grusbakken 12 DK – 2820 Gentofte	+45 (2335) 7909 +45 (4593) 4983 laa@liqtech.com
NGK	NGK EUROPE GmbH Jochen Scheer Westerbachstrasse 32 D – 61476 Kronberg	+49 6173 993 133 +49 6173 993 170 jscheer@ngk-e.de;
PHYSITRON	Physitron GmbH W.Karsten Am Merzenborn 6 D-56422 Wirges	+49 (2602) 1066 247 +49 (2602) 1066 248 waldemar.karsten@physitron.de

PIRELLI	Pirelli & C ECO Technology S.v.A. Tiziano Ambrosini Viale Luraghi snc I – 20020 Arese (MI)	+39 (02) 9387 4600 +39 (02) 9387 4660 Tiziano.ambrosini@pirelli.com
PROVENTIA	Proventia Emission Control Oy Petri Saari Tietotie 1 FIN-90460 Oulunsalo	+358 (20)781 0200 +358 (20) 781 0201 +358 (400) 297 097 Petri.saari@proventia.com
PURITECH	PURIttech GmbH & Co KG B.Kahlert Badstrasse 26 D-79761 Waldhut-Tiengen	+49 (7741) 966 820 +49 (7741) 966 8221 bernhard.kahlert@puritech.de
SAINT-GOBAIN	Saint Gobain IndustrieKeramik Rödental GmbH Stefan Mokos Postfach 1144 D – 96466 Rödental	+49 2203 / 956 454 +49 173 / 2716421 Stefan.Mokos@saint-gobain.com
TEHAG	TEHAG Engineering AG B.Franken Ratihard 1 CH – 8253 Diessenhofen	+41 (52) 646 0114 b.franken@tehag.com

9. Acronyms

- AEEDA Association Européenne d'Experts en Dépollution des Automobiles, Belgium
- AFHB Laboratory for Exhaust Emissions Control, University of Applied Sc. Biel
- AKPF Working group particle filter manufacturer
- AQCC Air Quality Control Company, Tehran
- ASTRA Swiss Federal Roads Office (FedRo)
- AUVA Austrian occupational health agency
- BAT Best Available Technology
- BAFU Swiss Federal Office of the Environment (FOEN)
- BG BAU (formerly TBG) German Builders Association
- BJ-EPB Beijing- Environment Protection Bureau
- BUWAL Now known as BAFU (FOEn)
- CARB Californian Air Resources Board
- CONAMA Comisión Nacional del Medio Ambiente – Chile
- CRAMIF Caisse régionale d'assurance maladie d'île de France
- CRT Continuously Regenerating Trap. Johnson Matthey patent
- DEEP Diesel Emission Evaluation Program (Canadian mines)
- DOE Department of Emissions, Tehran
- DTI Danish Technological Institute
- ECFE elemental carbon filtration efficiency
- EMPA Swiss Federal Laboratories for Materials Testing and Research
- ETH Swiss Federal Institute of Technology, Zurich
- IARC International Agency for Research on Cancer
- INRS Institut national de recherche de santé et sécurité au travail
- LEZ Low Emission Zone
- MMT Ministerio del Medioambiente de Chile
- MSHA US Mine Safety and Health Authority
- ND no data
- nm Nanometer = 10^{-9} m
- OBC on board control with logging and alarm functions
- op.h. operating hours
- PAH Polycyclic Aromatic Hydrocarbons
- PCFE particle counts filtration efficiency
- PFS Particle Filter System
- PM Particulate Matter = total particulate mass at < 52 °C,
- PN particle number [PN/cc; PN/km; PN/kWh]
- SN Swiss National Standard www.snv.ch
- SDA Secretaria del Ambiente/Bogotá
- SUVA Schweizerische Unfallversicherung / Swiss occupational health agency
- TOC Toxic Air Contaminant
- TRGS German technical directive on toxic substances
- TTM Technik Thermische Maschinen, Switzerland
- UBA German ministry of the environment, Berlin
- UN-ECE-PMP UN-Economic Commission for Europe. Particle Measurement Program
- VECC Vehicle Emissions Control Center / PR of China
- VERT Project to curtail emissions at tunnel construction sites
(Joint R&D project of the Suva + TBG + AUVA + BUWAL, 1994–99)
- VERT® Verification of Emission Reduction Technology; registered trademark of the
VERT® Association; www.VERT-certification.eu
- VFT VERT particle Filter suitability Test
- VFT1 VERT Filtration Test
- VFT1a VERT Filtration Test for filters for short duration use
- VFT2 VERT monitored Filter Test during at least 2,000 real world operation hours
- VFT3 VERT Filtration Test of PFS after successfully completing the VFT2
- VFKT VERT Test of electronic PFS monitoring

- VAST VERT Test of additive (FBC) dosage system
- VROM Netherlands Ministry of Housing, Spatial Planning and the Environment
- VSET VERT Secondary Emissions Test

10. References

- [1] Technische Anleitung zur Reinhaltung der Luft [TA Luft]; erste Fassung 1974
- [2] Schweizerische Luftreinhalte-Verordnung (LRV) vom 16. Dezember 1985
(Status 19.9.2008) SR 814.318.142.1
- [3] VERT-Verminderung der Emissionen von Real-Dieselmotoren im Tunnelbau –
Ein Verbundprojekt von Suva, AUVA, TBG und BUWAL (1993–1999),
<http://www.suva.ch>
- [4] Particle Filter Retrofit for Diesel Engines (Minimierung der Partikelemission von
Verbrennungsmotoren), A. Mayer und 82 Mitautoren, Expert-Verlag, 2008,
ISBN 978-3-8169-2850-8
- [5] BAFU-Filterliste: geprüfte und erprobte Partikelfiltersysteme für die Ausrüstung
von Dieselmotoren. UV-0829-D (oder F, I, E), www.umwelt-schweiz.ch/uv-0829-d
- [6] SN 277206 Prüfung von Partikelfiltersystemen für Verbrennungsmotoren,
Schweizerische Normen-Vereinigung
- [7] VERT-Pflichtenheft Regenerations-Additive; www.VERT-certification.eu
- [8] VERT-Pflichtenheft elektronische Filterkontrolle; www.VERT-certification.eu
- [9] Particle Measurement Programme (PMP) Final Report JRC 2007; EUR 22775 EN
www.jrc.ec.europa.eu
- [10] EU-Directive Euro 5/6 für PKW: EC-Regulation No. 715/2007, June 2007
http://ec.europa.eu/enterprise/automotive/index_en.htm
- [11] US Clean Air Act 202
- [12] Swiss EJPD directive 8/1990
- [13] SAE 2009-01-0284, Testing of Combined DPF+SCR Systems for HD retrofitting –
VERTdePN; J.Czerwinski et al.
- [14] SAE 2011-01-1139, Diesel Emissions with DPF+SCR in VERTdePN –
Testing & procedure; J.Czerwinski et al.
- [15] IARC/WHO Diesel Engine Exhaust Carcinogenic to Humans (Group 1) – press
release Nr. 213, 12. Juni 2012

11. Appendices

11.1. VERT[®] Acceptance Test Report for PFS

Particle filter	
Manufacturer (Brand)	
Number	
Type	
Identification (e.g. part number)	
Conformity number (VFT3 test number)	
Serial number	
Fitting Date	
Data logger	
Type	
Additive dosage system	
Type	
Vehicle / Machine	
Category (construction machine, bus, ..)	
Manufacturer	
Type	
Manufacturing year	
Chassis number	
Engine	
Manufacturer	
Type	
Manufacturing year	
Rated power [kW]	
Operating hours or km driven till PFS fitting	
Measurements without PFS	
Opacity K-value [1/m] during free accel.	
Noise [dBA] in near-field 45°/0.5 m	
At engine RPM [1/min]	
Measurements with PFS	
Opacity K-Value [1/m] during free accel	
Noise [dBA] in near-field 45°/0.5 m	
At engine RPM [1/min]	
Filter back-pressure [mbar]	
At RPM [1/min] and load [%]	
Opacimeter	
Manufacturer	
Type	
Sound Level Meter	
Manufacturer	
Type	
Test-Date and Responsibilities	
Test date	
Test center	
VERT [®] label running number	
Signature of the PFS retrofitter	
Signature of the buyer/operator	

1.2. Das VERT®- Gütesiegel



VERT „Verification of Emission Reduction Technologies“ ist seit dem internationalen VERT-Projekt (Schweiz, Deutschland und Österreich) zur Einführung von Partikelfiltern am Arbeitsplatz 1993-98 der Begriff für nachgerüstete Partikelfilter höchster Abscheidung im Blick auf die kompromisslose Minimierung dieser kanzerogenen Schadstoffe von Verbrennungsmotoren in der Atemluft.

Das **VERT**® Gütesiegel, eingesetzt ab Sept. 2002 ist weltweit im Markt bekannt als Zeichen für Partikelfilter höchster Qualität und Zuverlässigkeit. Es ist inzwischen auf über 22'000 nachgerüsteten Dieselgeräten appliziert, mehrheitlich bei Baumaschinen in der Schweiz, aber auch in anderen europäischen Ländern, in USA, Kanada, Chile und China.

VERT® ist als Marke in allen wichtigen Industrieländern geschützt, auch als VERT-DPF und VERT-certified.

Das VERT-Gütesiegel ist mit dem Namen des Filtersystemherstellers und einer Laufnummer ausgestattet, damit ist jeder nachgerüstete Filter individuell gekennzeichnet und sowohl für den Betreiber, als auch für den Hersteller und die Behörde verfolgbar. Die Randmarkierung dient zur Dokumentation des Nachrüstdatums.

Das Recht zur Verwendung dieses Gütesiegels haben nur Hersteller, deren Produkte nach dem weltweit strengsten Prüfverfahren für Partikelfilter, dem VERT-Zertifikationsverfahren geprüft wurden und auf der VERT-Liste aufgeführt sind – siehe www.VERT-certification.eu

Diese Prüfung setzt unter anderem voraus, dass die Filter sowohl im Neuzustand als auch nach einem Dauereinsatz in Feld über 2'000 Betriebsstunden einen Abscheidegrad von > 98 % für alle Partikel im alveolengängigen Grössenbereich 10-500 nm erzielen, dass sie keinerlei toxische Nebenprodukte emittieren, einen Gegendruck von < 200 mbar einhalten, das Geräuschniveau nicht und den Brennstoffverbrauch um nicht mehr als 2 % erhöhen. Weitere Forderungen bezüglich Funktion, Zuverlässigkeit, Lebensdauer, konstruktiver Ausführung, Bezeichnung, Wartung und Gewährleistung sind in der VERT-Filterliste nachzulesen.

Träger der Zertifizierung ist der VERT-Verein, NGO mit der Zielsetzung, die Minimierung der motorischen Emissionen nach BAT-Standard in Forschung und Anwendung weltweit zu fördern. VERT delegiert die Prüfung der Filtersysteme im Labor und im Feld nach der Norm SN 277206, die VERT zusammen mit Schweizer Behörden erarbeitet hat, an akkreditierte Labors wie AFHB-Biel, HTWD-Dresden, TÜV-Hessen, SWRI-San Antonio und andere. Die Prüfung der Konformität der Testergebnisse mit den VERT-Qualitätsanforderungen obliegt dem unabhängigen Scientific Committee des VERT-Vereins.

Diese Zertifizierung alleine aber genügt nicht für die Anwendung des VERT-Gütesiegels. Vielmehr muss jeder Filter beim Einbau bezüglich Abscheidegrad, Gegendruck und Geräuschemission überprüft werden und alle Spezifikationen von Fahrzeug und Filter müssen im VERT-Prüfprotokoll notiert und von Nachrüster und Betreiber durch Unterschrift bestätigt werden. Erst dann können die Daten in die öffentlich zugängliche VERT-Datenbank übernommen werden und die Nachrüstung kann durch Behörden wie die Schweizer Strassenbehörde ASTRA freigegeben werden.
VERT, 28.5.2012

11.3. Particle Filter Systems for Internal Combustion Engines

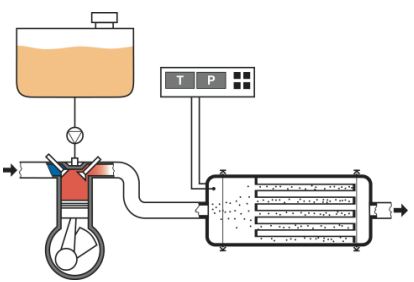
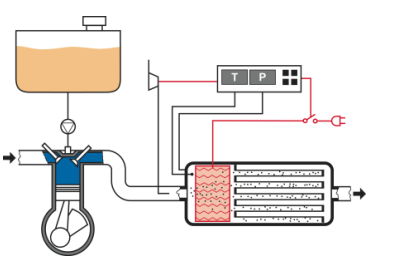
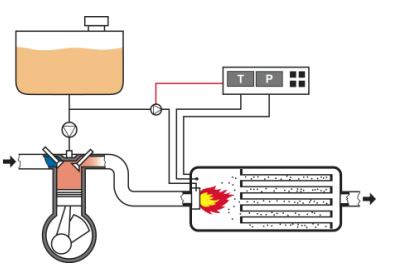
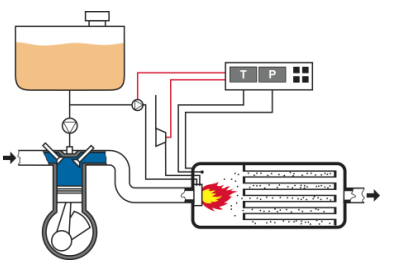
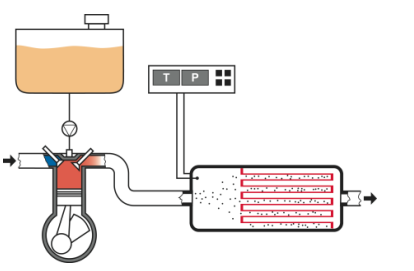
1		<p>Filter Substrate exchanged for Regeneration offline Very often applied in mines and for forklifts, where regeneration conditions might be difficult. Filter substrate is not catalytically coated; can be easily exchanged via V-clamps and is regenerated offline by electricity or hot air. Clean substrate is installed immediately with very little downtime. A low-cost system with however needs regular maintenance.</p>
2		<p>Electric Regeneration onboard A classic system solution with slow and riskless over-night regeneration. Often applied in bus fleets, fleets of waste collectors, fire fighter vehicles or others where vehicles can be plugged-in over-night. No problem of secondary emission formation.</p>
3		<p>Full-flow Fuel Burner Guarantees regeneration under all operation conditions but requires a rather complex system control to sustain a clean burning flame under all engine load and speed conditions, stationary and also transient. Very successfully applied in locomotives and larger construction machines. No risk of secondary emissions.</p>
4		<p>Standstill Burner Very often used in small construction machines and forklifts where operation conditions are hardly predictable and long idling or low load operation might happen. An air compressor is required if the engine is at standstill during the regeneration process but air supplied by the engine might also be used at idle conditions. No risk of secondary emission formation.</p>
5		<p>Catalytic Coated Filter A coated catalyst can support the ordinary oxygen combustion of soot, accelerate the soot combustion process and lower the ignition temperature to below 350 °C. Mostly transition metals are used also in combination with rear-earth substances. Regeneration is fast and very efficient but a minimum temperature window is required one or two times per day. Certification must check for possible secondary emissions.</p>

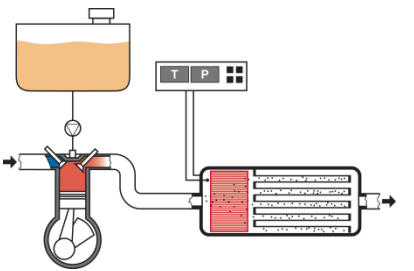
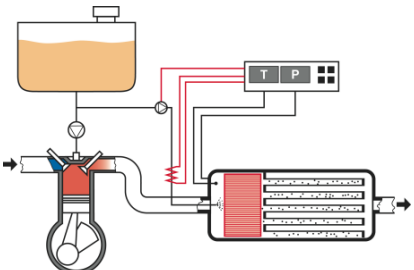
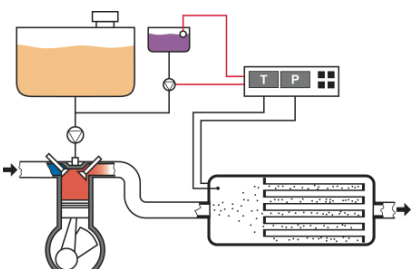
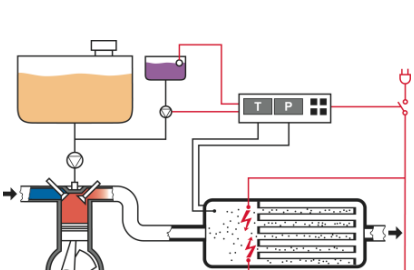
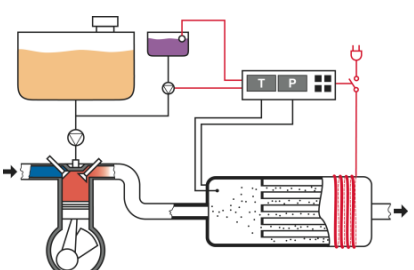
6		<p>CRT-System: uncoated filter with upstream DOC Continuous Regeneration Trap – an ingenious invention by Johnson Matthey in 1988 could not be applied until fuel sulfur was reduced to values below 20 ppm. Now widely applied in road vehicles. Pt-coating converts NO to NO₂, which splits again into NO and atomic O, which can burn soot at temperatures as low as 230 °C; a slow but elegant process; some NO₂-slip is unavoidable.</p>
7		<p>Catalytic Fuel Burner Diesel-Fuel, finely distributed, maybe preheated or even a bit reformed to create more H₂ and CO and injected on at the surface of a standard DOC will start flameless combustion above 200 – 250 °C and can develop sufficient heat to burn the soot stored in the filter. A well controllable active regeneration system, combined with the CRT effect. Some NO₂-slip is to be expected.</p>
8		<p>FBC = Fuel Borne Catalyst Transition metals are mixed to the fuel in metalorganic form (5-20 ppm) and transformed to catalytically active oxide clusters in the size of 3-10 nm. Attached to the soot particles they catalyse the combustion process at temperatures of 350°C. Combustion is fast and very efficient. Some FBC like Fe are sulfur tolerant to S>7000 ppm. FBC do not age. Concentration can easily be adjusted to the required level also automatically.</p>
9		<p>FBC with active Ignition Regeneration of a soot cake additized by FBC oxide clusters can be triggered by a local heat source. To conduct the heat to the depth of the filter in order to clean it completely the filter material should be heat conductive. Certain exhaust gas conditions like temperature and oxygen content are required to avoid interruption of the regeneration process.</p>
10		<p>FBC with active Ignition = SMF[®]-AR A system which is widely used for construction machines or other applications which have particularly demanding and unpredictable operating conditions. The sinter metal substrate provides the heat conductivity and the local ignition at the downstream part of the filter leads to a flame propagation towards the intake. A very fast, well controllable and efficient regeneration method.</p>

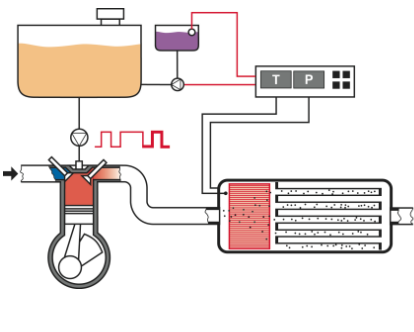
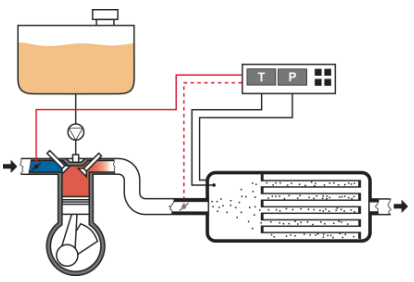
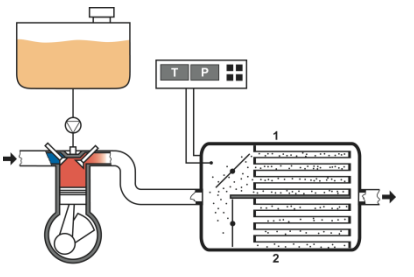
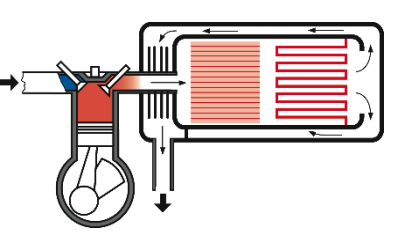
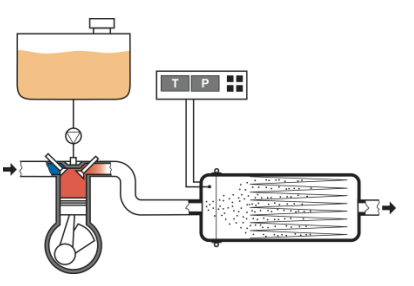
11		<p>FBC + CRT: the PSA system 5/2000 with temperature management by retarded injection</p> <p>Some application require either active filter systems or management of the exhaust temperature such that a passive system reaches his operation window. In 2000 PSA used the electronic control of the injection timing to retard injection whenever regeneration was required. Exhaust temperature reached a level to trigger flameless post combustion on the DOC in order to generate enough temperature for FBC regeneration.</p>
12		<p>Temperature Management by Throttling</p> <p>Throttling of intake air or exhaust gas is another very efficient measure to rise exhaust temperatures to near full-load levels. To avoid increase of fuel consumption due to back pressure losses the throttling phase must remain short. Combination with FBC to trigger a self-sustained combustion process is recommended.</p>
13		<p>Temperature Management by Heat Storage</p> <p>Use phases of high exhaust gas temperatures to warm up and regenerate one filter element while passing cold gas to the neighbor element is another technical system to cope with changing operation conditions. Twin filter systems, also with active burners, were widely used in the beginning but seem to disappear because of their higher complexity.</p>
14		<p>Temperature Management by Heat Recuperation</p> <p>Small temperature increments due to catalytic conversion or filter regeneration can be recuperated to increase the temperature, stabilize and accelerate the process. Fast regenerations are possible. The process is fully passive but self-regulating. Heat losses and heat transfer determine the overall efficiency.</p>
15		<p>Disposable Filter</p> <p>Filter materials based on organic fibers are available which can tolerate temperatures as high as 300°C, glass fibers permit over 600 °C. Industry offers low cost cartridges with pleated paper structures which permit the design of soot filters collecting and storing soot during several hundred hours. After reaching the permissible backpressure they are disposed as industrial waste. Efficiencies can easily reach VERT-limits of > 97 %.</p>

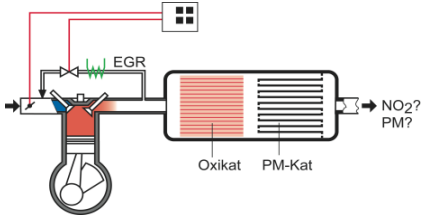
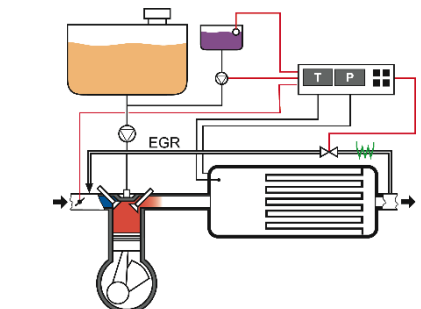
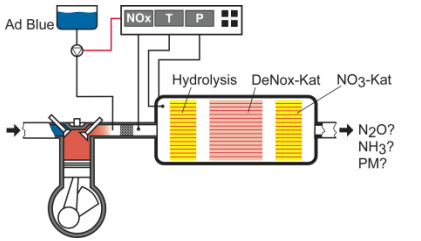
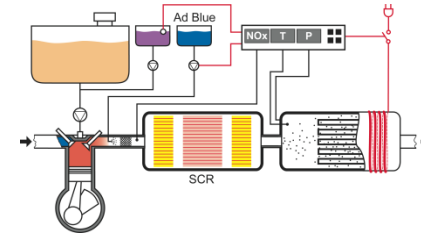
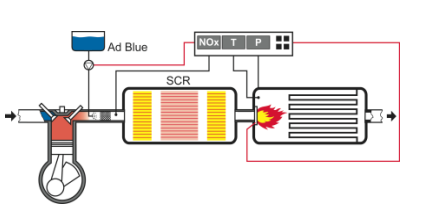
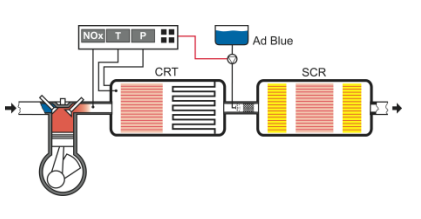
16.		<p>High-Pressure EGR and Filtration Unregulated EGR as it is still used for some older generation Diesel engines will be influenced by varying backpressure of a filter system and even more by throttling. In this case backpressure should remain below 120 mbar while in all other cases 200 mbar are admissible. The better solution is of course the close-loop control of the EGR-valve and interrupt EGR during throttle intervention.</p>
17.		<p>FBC-Filter with Low-Pressure EGR Recirculate exhaust gas from downstream filter – also called “clean gas induction” is recommended instead. Contamination of the EGR system, the cooler and the engine can be avoided and even higher EGR-rates are permitted. Regulation however might be more difficult</p>
18.		<p>SCR classic without Filtration NOx reduction by selective catalytic reaction using ammonia or urea as reductant substances also requires a minimum exhaust temperature of > 230 °C and creates backpressure the flow resistance of the catalyst and the mixers. It also requires about as much space as a particle filters. The challenge is therefore to use either SCR or DPF or to solve the difficult problem to combine both.</p>
19.		<p>SCR upstream active FBC-Filter DPF downstream of SCR might suffer from lower exhaust temperatures. An active filter system like SMF[®]-AR can solve this problem. This solution is in place in trucks and buses</p>
20.		<p>SCR upstream Full Flow Burner Filter Another active solution with a full flow burner, a standstill burner or an idle burner might also solve this problem. These 2 solutions are recommended in all cases where vehicles homologated with SCR shall be retrofitted.</p>
21.		<p>SCR downstream CRT-Filter If the vehicle has no SCR yet but shall be equipped with a deNOx-System and an efficient filter the arrangement can be freely selected. Recent development however has demonstrated that an even better solution will be to coat the SCR on the filter surface itself – the so-called SDPF, which can bring the space requirement again back to the size of the silencer to be replaced.</p>